

# GEORGE FOREMAN®



**24002**

 [www.georgeforemangrills.com](http://www.georgeforemangrills.com)

**£10,000 prize draw**

EXTRA year guarantee FREE rewards gallery

[www.georgeforeman.co.uk/productregister/](http://www.georgeforeman.co.uk/productregister/) Register online now! See back for details

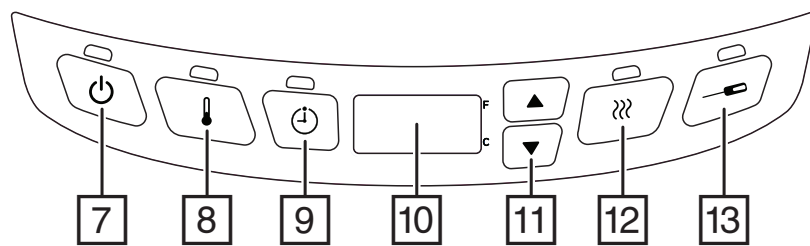
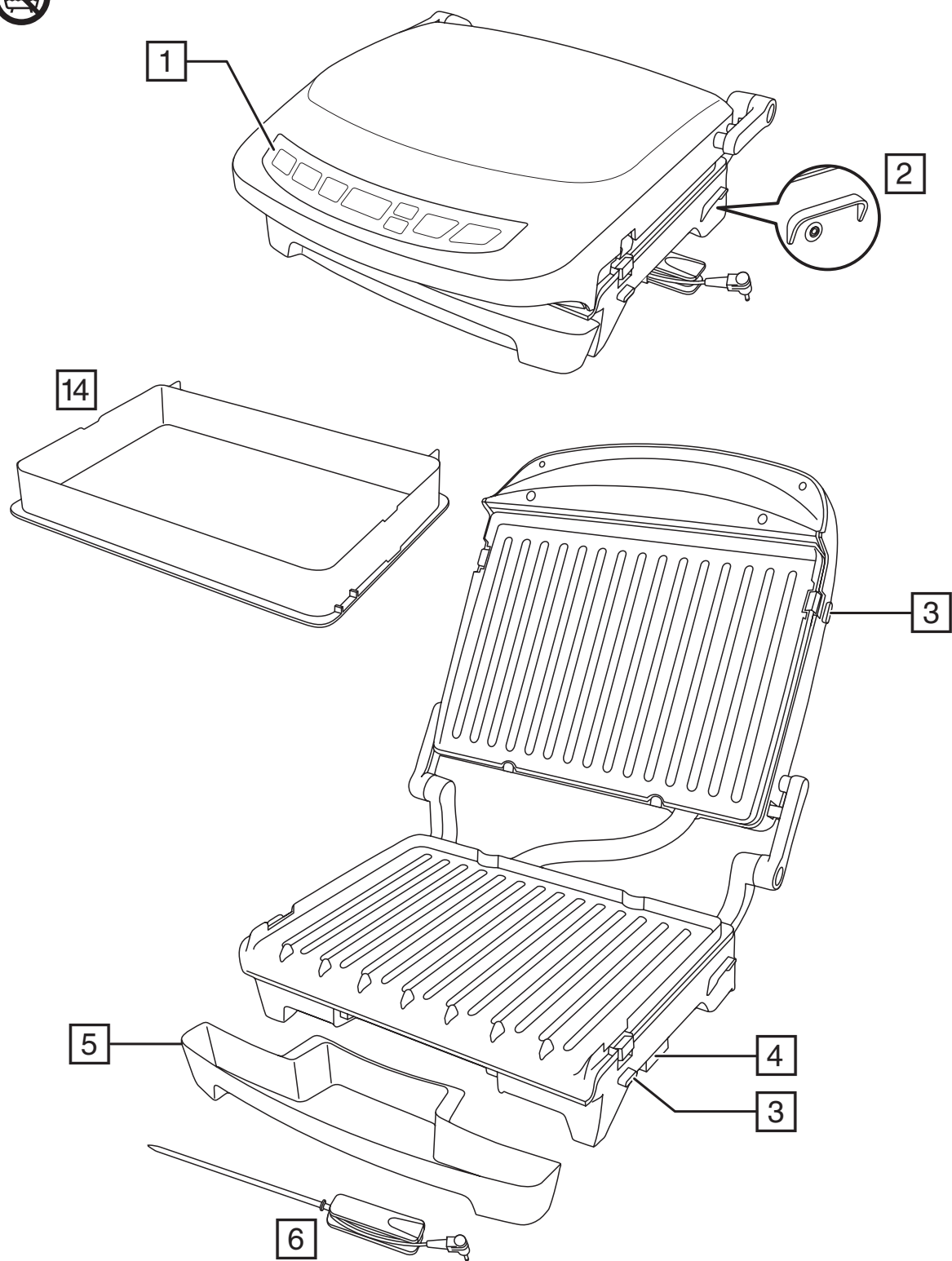

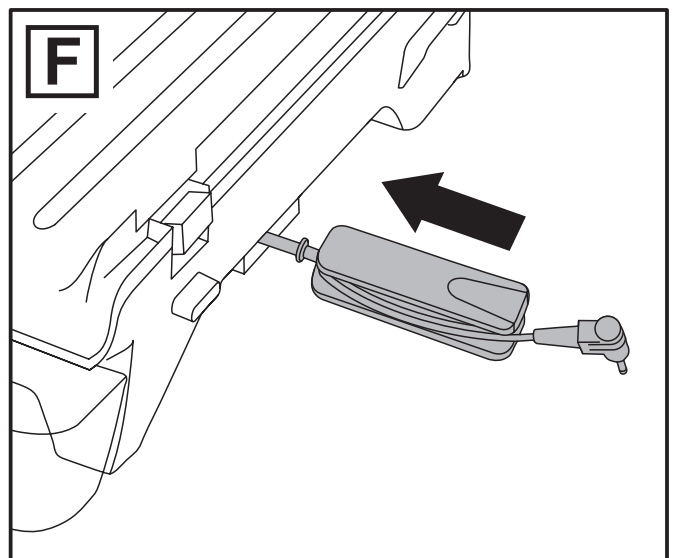
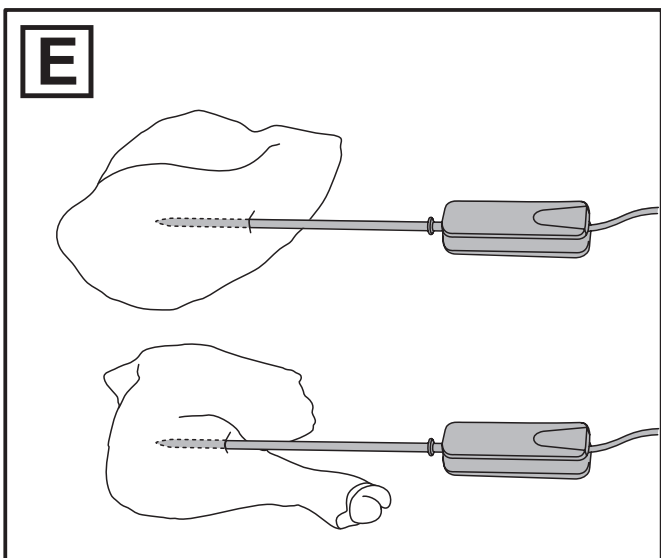
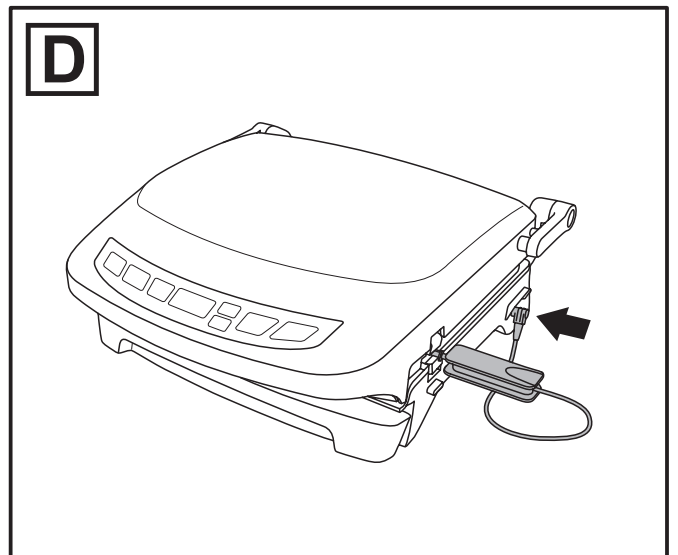
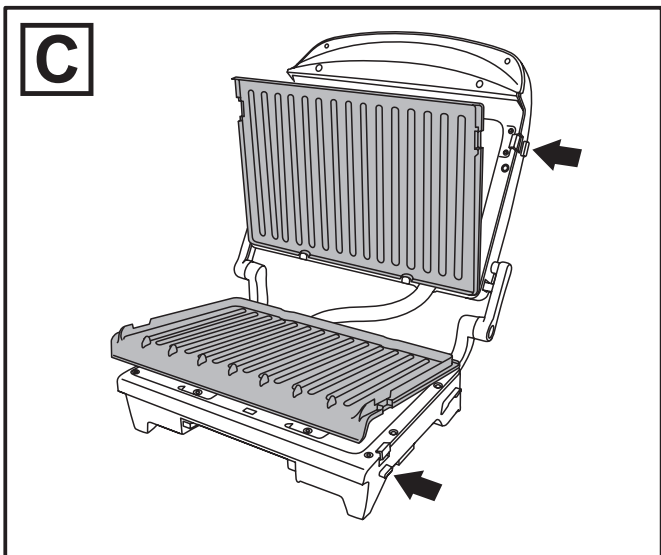
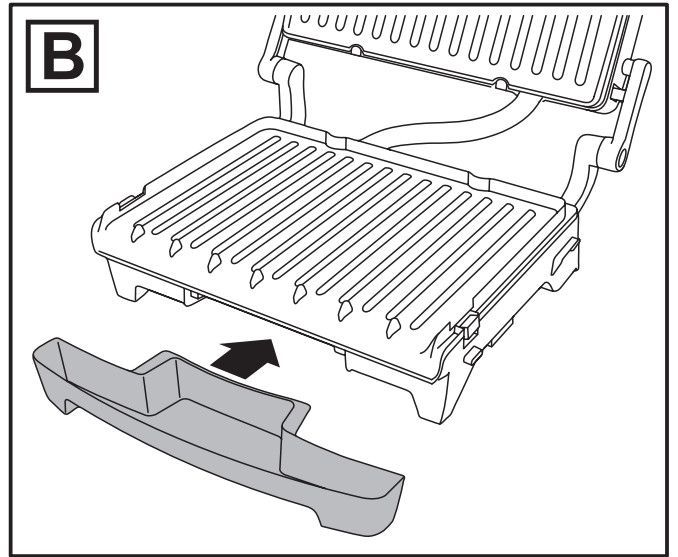
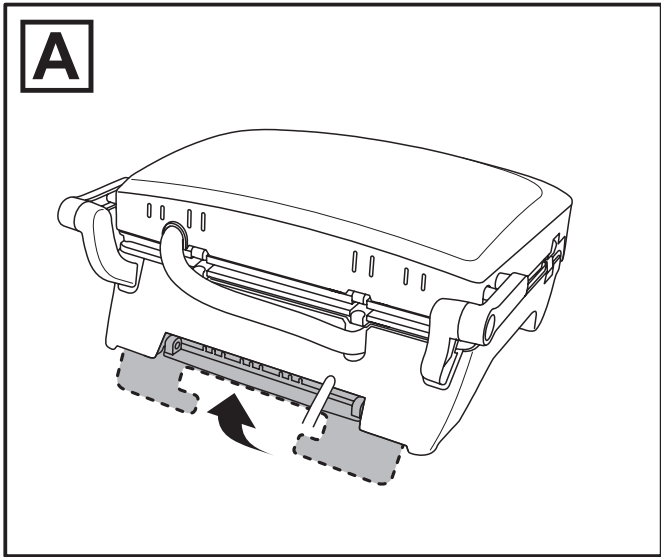

Read the instructions, keep them safe, pass them on if you pass the grill on.  
Remove all packaging before use.

---

## IMPORTANT SAFEGUARDS

Follow basic safety precautions, including:

This appliance can be used by children aged from 8 years and above and persons with reduced physical, sensory or mental capabilities or lack of experience and knowledge if they have been supervised/instructed and understand the hazards involved. Children shall not play with the appliance. Cleaning and user maintenance shall not be done by children unless they are older than 8 and supervised.

Keep the appliance and cable out of reach of children under 8.

Don't connect the appliance via a timer or remote control system.

⚠ The surfaces of the appliance will get hot during use.

If the cable is damaged, return the appliance, to avoid hazard.

- ⊘ Do not use this appliance near bathtubs, showers, basins or other vessels containing water.
- Don't wrap food in plastic film, polythene bags, or metal foil. You'll damage the grill and you may cause a fire hazard.
- Don't use the grill for any purpose other than cooking food.
- Don't use the grill if it's damaged or malfunctions.
- Always wear a protective oven glove when opening the grill, or placing/removing food.

### HOUSEHOLD USE ONLY

---

## PARTS

- |                            |                                   |
|----------------------------|-----------------------------------|
| 1. Control panel           | 8. Temperature button and light   |
| 2. Probe connector         | 9. Timer button and light         |
| 3. Plate release buttons   | 10. Display                       |
| 4. Probe storage           | 11. Adjust buttons                |
| 5. Drip tray               | 12. Sear/Steak button and light   |
| 6. Probe                   | 13. Probe select button and light |
| 7. On/off button and light | 14. Deep plate                    |

---

## BEFORE USING FOR THE FIRST TIME

Wipe the grill plates with a damp cloth.

Your grill may smoke a little the first time you use it. This is normal and will soon disappear.

---

## TILTING/LEVELLING THE GRILL

You can tilt your grill so that fat and juices run into the drip tray when cooking things like burgers, meat, etc. Alternatively, you can use your grill level for cooking things like panini, sandwiches, etc.

To tilt your grill extend the foot downwards below your grill (FIG A). Fold the foot flat again to level your grill.

---

## PLATES

The grill plates are best for grilling meat, sausages and anything that might give off fat. Use with the grill in the tilted position. Deep plate—the deep plate is ideal for cooking non-fatty items, pizza, baking, pittas, calzone and batters (e.g. Yorkshire pudding). Use it with the grill in the level position. You must always have the upper grill plate fitted when using the deep plate.

### Removing the plates

1. Open the grill. Remove one plate at a time.
2. Press the plate release button and lift the plate away from the grill (FIG C).

### Fitting the plates

1. Fit one plate at a time.
  2. Put the tabs into the slots on the hinge side of the appliance.
  3. Press the other edge of the plate into the handle side, to lock it in place.
- At the places where the top and bottom plates make contact, the non-stick surfaces may show signs of wear. This is purely cosmetic, and will not affect the operation of the grill.

---

## USING YOUR GRILL

Your grill has five operating modes:

- Basic grilling function
- Simple steak function
- Sear function
- Temperature probe function
- Timer function

---

## CHANGING TEMPERATURE UNITS

You can choose to display the temperature units in °C (default) or °F. To change the units, press both ▲ and ▼ buttons firmly and hold them for three seconds. The grill will beep and the ● marker on the display will move to show whether the display is reading in °C or °F.

---

## BASIC GRILLING

Use the basic grilling function for simple grilling, panini, sandwiches, etc.

- Sit the grill on a stable, level, heat-resistant surface, away from cupboards, curtains, etc.
  - Slide the drip tray between the two runners underneath the front of your grill (FIG B). Slide the tray all the way in. The drip tray will collect any fat or juices that run off the plates during cooking.
  - Decide whether you want the grill level or tilted —see *TILTING/LEVELLING THE GRILL*.
1. Plug the grill in. The grill will beep and the red power light will flash slowly.
  2. Press the ⏻ button. If you don't press the ⏻ button within 2 minutes, your grill will enter sleep mode and the red power light will stop flashing. Press the ⏻ button again to wake your grill.
  3. The light above the temperature (Ⓛ) button will come on and the display will show **175** (default). The default temperature units are in °C which can be changed to °F if desired—see *CHANGING TEMPERATURE UNITS*.
  4. Set the temperature you require using the ▲ and ▼ buttons. The range is from 150°C to 220°C in 5° steps (302°F to 428°F in 9° steps).
  5. While your grill is heating up, the light above the temperature button will light up red, and the figures on the display will flash. When your grill has reached the selected temperature, the light will turn green, the display will stop flashing and your grill will beep three times. During cooking, this sequence will be repeated as your grill maintains the temperature. This is normal.
  6. When the selected temperature has been reached place the food onto the grill and close the lid.
  7. When you have finished cooking press the ⏻ button then unplug the grill.
- You can adjust the temperature at any time using the ▲ and ▼ buttons.
  - Check that the food is cooked. If you're in any doubt, cook it a bit more.
  - Always use an oven glove when opening/closing the grill or placing/removing food.
  - Use wooden or plastic tools to prevent damage to the plates.
  - The grill hinge is articulated to cope with thick or oddly shaped foods.
  - The grill plates should be roughly parallel, to avoid uneven cooking.
  - When necessary, use an oven glove and empty the drip tray into a heatproof bowl. Wipe it with kitchen paper then replace it under the front of the grill.

---

## SIMPLE STEAK FUNCTION

The simple steak function combines your grill's sear feature with the temperature probe to provide a simple method to cook great tasting, juicy steaks. You can cook two or more similarly sized steaks at the same time. Insert the probe into one of them.

1. Connect the temperature probe to your grill (FIG D).
2. Press the ⏻ button.
3. Press the probe (—) button then immediately press the sear (⏏) button either once, twice or three times depending on how you want your steak cooked:
  - Once for rare (display will show ---)
  - Twice for medium (display will show ==)
  - Three times for well done (display will show ===)
4. Allow your grill to heat up. While the grill is heating up, insert the temperature probe into the thickest part of the steak. When it's ready, the light above the sear button will turn green and your grill will beep three times.
5. Open your grill and carefully lay the steak onto the lower plate.
6. Close your grill.
7. When the steak is cooked, your grill will beep five times. Open the grill and remove the steak straight away otherwise it will continue cooking and may become overcooked.
8. To cancel the function at any time, press the ⏻ button.
9. You can repeat the simple steak function four times one after the other but if you try to use it more than this the display will show "ERR" (ERRor). Press the ⏻ button and allow your grill to cool for 10 minutes before using the function again.





## Tips for perfect steaks

- Ideally, steak should be 12 - 15 mm thick (fillet steaks can be thicker).
- Always allow the steaks to come up to room temperature before cooking. Don't try to cook them straight from the fridge.
- Pat the steaks dry with kitchen paper before placing on the grill.
- Season just before cooking. Be sparing with the salt or leave it out altogether (you can always add salt for flavour after cooking). Adding salt before cooking can draw water to the surface of the steak where it will boil during cooking. The steak will be steamed rather than seared, and will be grey instead of brown.
- Resting steaks after cooking is crucial for the best results. Allow them to rest for a minimum of 3 minutes before serving. Correct resting allows the juices within the meat to be reabsorbed giving a tasty, succulent steak.

---

## SEAR FUNCTION

The sear function raises the temperature to 260°C for 90 seconds. The sear function works best with close-grained red meat like beef, lamb, venison, buffalo, bison, etc., cut into steaks (across the grain of the meat). The meat should be between 5 mm and 25 mm thick.

1. Press the  button.
2. Press the sear () button. The light above the sear button will light up red and the display will show **260**.
3. When your grill has reached the sear temperature, the light will turn green, the display will stop flashing and your grill will beep three times.
4. Wear an oven glove and open the grill. Place the food onto the bottom grill plate, then close the grill.
5. Wait till the grill beeps again (after 90 seconds) then open the grill and remove the food.
6. You can repeat the sear function four times one after the other but if you try to use it more than this the display will show "ERR" (ERRor). Press the  button and allow your grill to cool for 10 minutes before using the sear function again.
7. At the end of the sear function, your grill will revert to the previously set temperature. However, it will take time to cool down.
8. To cancel the sear function at any time, press the  button.

The outside surfaces of the food will be seared to a deep brown, while the inside should be rare to medium rare (depending on the thickness of the food).

You now have the option of removing the food right away, (for rare or medium), or leaving it to cook at the default temperature for a little longer if you want the meat more well done.







---

## TEMPERATURE PROBE FUNCTION

Many people judge if meat is cooked by touch or sight, or from the length of the cooking time. The use of the temperature probe has several benefits over these methods:

- Provide consistent, repeatable results
- Prevent overcooking
- Prevent illness due to under cooked food
- Eliminate guesswork

In use, the sharp point of the temperature probe is inserted into the food and the other end is connected to your grill. The probe constantly sends the internal temperature of the food to your grill where it is compared to a target temperature you have previously set. Once reached, your grill will sound an alarm and switch off.

1. Connect the temperature probe to your grill (FIG D).
  2. Press the  button.
  3. Set the cooking temperature you require using the  and  buttons and allow your grill to heat up.
  4. Press the probe () button. The light above the probe button will light up red and the display will show **75** (default).
  5. Set the probe temperature you require using the  and  buttons. The range is from 48°C to 81°C in 3° steps (113°F to 177°F in 5°/6° steps).
  6. Insert the temperature probe into the food and carefully place the food onto the preheated grill. Make sure that the probe doesn't affect the lid closing or that the cable isn't pinched when the lid is closed.
  7. During cooking, the display will alternate between showing the target temperature you have set and the temperature that the probe is actually reading. When the internal temperature of the food matches the target temperature, the light above the probe button will turn green and your grill will beep five times. The heaters of your grill will switch off when the target temperature is reached but since cooking will continue due to the residual heat, remove the food as soon as possible.
  8. To cancel the function at any time, press the  button.
- If you forget to plug in the probe the display will show "NO PRB" (NO PRoBe) and your grill will beep.
  - The probe will become HOT during use.
  - Always insert the probe into the thickest part of the meat away from any bone or fat which can give a false reading (FIG E).
  - For the most accurate temperature reading, make sure that the probe is placed as central as possible between the upper and lower surfaces of the meat.
  - Before and after use, clean the probe with warm soapy water, rinse and dry.
  - Store the probe by wrapping the cable between the two halves of the handle and inserting it into the recess on the side of your grill (FIG F).

---

## TIMER FUNCTION

Using the timer is optional. It doesn't turn your grill off, it simply beeps five times to tell you the time is up. Use the timer with the basic grilling function. To set the timer:

1. Switch on your grill and set the desired temperature. Allow it to heat up until the light above the temperature button turns green.
2. Press the timer (⌚) button the light above the button will come on and the display will flash **5:00** (default). Use the ▲ and ▼ buttons to set the desired time. The time can be set from 30 seconds to 19 minutes 30 seconds in 30 second increments. If you don't press either button within 5 seconds, the grill will revert to temperature mode.
3. The display will stop flashing and the timer will start to count down 5 seconds after you last press the ▲ or ▼ button.
4. When the timer reaches zero, the grill will beep five times and the display will flash **0:00**. Remember that your grill is still active and you must remove the food to avoid overcooking it.
5. To cancel the timer function at any time, press and hold the timer button for three seconds. Your grill will revert to the basic grilling function.

---

## ADVANCED COOKING

You can use the temperature probe feature to control exactly how you like your steak to be cooked (although for rare, medium and well done steaks, we strongly recommend using the simple steaks function already described. To cook a medium-rare or medium-well done steak, do the following:

1. Prepare the steak and insert the probe. Connect the probe to the grill.
2. Press the (⏸) button.
3. Set the temperature to 220°C using the ▲ and ▼ buttons.
4. Press the probe (📍) button. The light above the probe button will light up red and the display will show **75** (default).
5. Use the ▲ and ▼ buttons to set the desired probe temperature (refer to the COOKING TIMES AND FOOD SAFETY table).
6. Press the sear (🔥) button. The light above the sear button will light up red and the display will show **260**.
7. Wait until the light above the sear button turns green and the grill beeps three times. The light above the probe button will also light up red.
8. Open the grill and place the steak and probe onto the grill plate then close the lid.
9. When the steak is cooked, the light above the probe button will turn green and your grill will beep five times.
10. Immediately open the grill and remove the steak.

---

## COOKING TIMES AND FOOD SAFETY

The following times should be used purely as a guide. They are for fresh or fully defrosted food.

Food	Time (mins)	Probe Temp.	Grill Temp.	Notes
<b>MEAT</b>				
Steak: rare	-	51°C	220°C	We recommend using the simple steak function
Steak: medium rare	-	57°C	220°C	
Steak: medium	-	63°C	220°C	We recommend using the simple steak function
Steak: medium well	-	69°C	220°C	
Steak: well done	-	72°C	220°C	We recommend using the simple steak function
Pork chops/steaks	-	75°C	220°C	
Lamb leg steak: medium	-	69°C	220°C	
Lamb leg steak: well done	-	78°C	220°C	
Lamb chop: medium	-	63°C	220°C	
Lamb chop: well done	-	78°C	220°C	
Duck breast: medium	-	66°C	220°C	
Duck breast: well done	-	72°C	220°C	
Chicken breast	-	75°C	220°C	
Sausages	-	75°C	220°C	Insert probe lengthways down the centre of the sausage
Burgers	-	75°C	220°C	
Bacon	3-5	-	220°C	
<b>FISH</b>				
Salmon	3-5	-	200°C	
Prawns	1-2	-	200°C	
Flat fish	2-6	-	200°C	Plaice, Sole, etc.
Round fish	3-8	-	200°C	Haddock, Cod, etc.
Tuna / swordfish	5-10	-	200°C	

Food	Time (mins)	Probe Temp.	Grill Temp.	Notes
<b>VEGETABLES</b>				
Peppers	4-6	-	220°C	
Aubergine	6-8	-	220°C	Sliced
Asparagus	3-4	-	220°C	
Carrots	5-7	-	220°C	Sliced
Courgette	1-3	-	220°C	Sliced
Tomatoes	2-3	-	220°C	Halved
Onions	5-6	-	220°C	Cut into wedges
Mushrooms	3-6	-	220°C	Whole, flat mushrooms
Corn on the cob	4-6	-	220°C	
<b>OTHER</b>				
Haloumi	2-4	-	200°C	

- When cooking frozen foods, add 2-3 minutes for seafood and 3-6 minutes for meat and poultry (depending on the thickness and density of the food).
- Cook fish, prawns, etc., until the flesh is opaque throughout.
- If you aren't using the temperature probe, cook poultry, pork, burgers, etc., until the juices run clear.
- Check food is cooked through before serving. If in doubt, cook it a bit more.
- When cooking pre-packed foods, follow any guidelines on the package or label.

## CARE AND MAINTENANCE

1. Press , then unplug the grill and let it cool.
2. Wipe all surfaces with a damp cloth or sponge.
3. Use a paper towel with a dab of cooking oil to remove stubborn stains.
4. Wash the grill plates in warm soapy water, or in a dishwasher.
5. Wash the drip tray in warm soapy water, or in the top rack of the dishwasher.
6. Take extra care with the non-stick cooking surfaces.
  - Don't use harsh or abrasive cleaners, solvents, scourers, wire wool, or soap pads.
  - Where the top and bottom plates make contact, the non-stick surfaces may show signs of wear. This is purely cosmetic, and will not affect the operation of the grill.

## RECIPES

### CHILLI AND LIME BUTTERFLY CHICKEN Serves 4

Preparation time: 5-10 minutes plus 2 hours marinating time. Cooking time: approx. 8-10 minutes

- 4 butterflied chicken breasts
  - 3 tbsp chilli powder
  - 2 tbsp olive oil
  - juice and zest of 1 lime
  - 4 garlic cloves, finely chopped
  - 1 tsp ground coriander
  - 1 tsp ground cumin
1. Mix together all of the ingredients (except the chicken) to make a marinade. Pour the marinade over the chicken making sure it is covered. Cover with cling film and leave to marinate in the fridge for at least 2 hours.
  2. Pre-heat your grill to 220°C and set the probe to 75°C. Insert the probe into the centre of the largest piece of chicken and cook until the probe alarm goes off.

### SAUSAGE AND HERB STUFFED PORK Serves: 4

Preparation time: 10-15 minutes. Cooking time: approx. 8-12 minutes

- 250g sausage meat
  - 30g fresh breadcrumbs
  - 2 tbsp fresh parsley
  - ½ tsp dried thyme
  - ½ tsp dried marjoram
  - 1 tsp black pepper
  - 2 whole pork fillets
1. Mix the sausage meat, marjoram, thyme, parsley, and pepper together.
  2. Cut each pork fillet into two then cut a slit into each piece to make a pocket. Stuff the pockets with the sausage mixture and fasten the edges together with the cocktail sticks.
  3. Pre-heat your grill to 220°C, and set the probe to 75°C. Insert the probe into the middle of the largest piece of pork and cook until the probe alarm goes off.



## **HONEY AND MUSTARD PORK LOIN STEAK Serves: 4**

Preparation time: 5-10 minutes. Cooking time: approx. 8-12 minutes

- 4 pork loin steaks
  - 2 tbsp whole grain mustard
  - 80g honey
  - 50g dark brown sugar
  - 2 tbsp olive oil
  - Salt and pepper to taste
1. Mix together the mustard, honey, sugar, olive oil, salt and pepper. Pour the mixture over the pork steaks, cover with cling film and leave to marinate in the fridge for at least 2 hours.
  2. Pre-heat your grill to 220°C and set the probe to 75°C. Insert the probe into the centre of the biggest piece of pork and cook until the probe alarm goes off.

## **SZECHUAN TUNA STEAKS Serves: 4**

Preparation time: 5 minutes plus 40 minutes marinating time. Cooking time: 4-6 minutes

- 4 tuna steaks, approx. 2-3 cm thick
  - 60ml soy sauce
  - 2 tbsp rice vinegar
  - 1 tsp sugar
  - 1 tbsp sesame oil
  - 1 tbsp chilli oil
  - 1 clove garlic, crushed
  - 1 tbsp ground Szechuan pepper corns
  - 3 tbsp coriander, chopped
1. Combine the soy sauce, vinegar, sugar, sesame oil, hot chili oil, Szechuan pepper and garlic.
  2. Set aside 2 tablespoons of the mixture and pour the remainder over the tuna steaks. Cover with cling film and refrigerate for 40 minutes, turning once.
  3. Pre-heat your grill to 220°C and grill the tuna steaks for 4-6 minutes until the tuna is opaque but still feels soft in the centre.
  4. Cut each tuna steak into thin slices lengthwise. Pour the reserved sauce over the sliced tuna and sprinkle with fresh chopped coriander.

## **GRILLED SALMON WITH LEMON BASIL BUTTER Serves: 4**

Preparation time: 10-12 minutes. Cooking time: 5-10 minutes

- 4 salmon fillet portions approx. 200g each
  - 1 tsp paprika
  - 1 tsp cracked black pepper
  - 100g butter, melted
  - 1 tbsp fresh basil, finely minced
  - 1 tbsp fresh lemon juice
  - 1 spring onion, finely chopped
1. Rub the salmon with paprika and pepper on both sides and leave to marinate for 5-10 minutes.
  2. Pre-heat the grill to 220°C and cook the pieces of salmon for approx. 5 minutes until the fish starts to flake and is cooked through.
  3. For the lemon basil butter, mix the butter, basil, lemon juice and spring onions together.
  4. To serve, arrange each piece of salmon on a plate with some steamed vegetables and top with a generous spoonful of the lemon basil butter.

## **TANDOORI GRILLED CHICKEN Serves: 4**

Preparation time: 5-10 minutes plus 2 hours marinating time. Cooking time: 10-15 minutes depending on size

- 2 boneless, skinless chicken breasts
  - 200g natural yogurt
  - 1 tbsp lemon juice
  - 2 tsp paprika
  - 2 garlic cloves, minced
  - ½ tsp ground ginger
  - ½ tsp cumin
  - ½ tsp cayenne pepper
  - ½ tsp cinnamon
1. Mix the yogurt, lemon juice, paprika, garlic, ginger, cumin, cayenne and cinnamon together. Cut each chicken breast into two equal pieces and add them to the marinade. Make sure the chicken is well coated with the marinade. Cover with cling film and refrigerate for at least 2 hours.
  2. Pre-heat the grill to 220°C and set the probe to 75°C. Insert the probe into the middle of the biggest piece of chicken and cook until the probe alarm goes off. Discard any remaining marinade.

## **CREAM CHEESE CHICKEN PARCELS Serves: 2**

Preparation time: 15-20 minutes. Cooking time: 10-15 minutes

- 1 chicken breast, skinless and boneless
  - 2 flour tortilla wraps
  - 100g cream cheese
  - 100g fresh baby spinach leaves
  - 1 tsp mustard powder
  - 1 tsp grated nutmeg
  - 1 tsp pepper
1. Pre heat the grill to 220°C and set the probe to 75°C. Insert the probe into the centre of the thickest part of the chicken breast. Grill the chicken until the probe alarm goes off. Remove the chicken from the grill, let it cool, and cut into strips.
  2. Wash and dry the spinach. Place the leaves onto the grill for 20-30 seconds then remove them and dry with kitchen paper.
  3. Mix the cream cheese and spinach together and then fold in the chicken strips. Spoon the mixture into the centre of the tortilla wraps. Fold over one end of the tortilla then roll the wraps up. Warm the filled wraps on the grill for 2-3 minutes.

## **HERBED CHICKEN AND MUSHROOM KEBABS Serves: 4**

Preparation time: 25-30 minutes including marinating time. Cooking time: 8-12 minutes

- 2 chicken breasts, skinless and boneless
  - 500g button mushrooms
  - 1 tsp dried rosemary
  - 1 tbsp dried parsley
  - ½ tsp dried thyme
  - 30ml lemon juice
  - 2 tbsp white vinegar
  - 1 chicken stock cube
  - 1 tsp black pepper
1. Mix together the rosemary, parsley, thyme, lemon juice, vinegar, stock cube, salt and pepper. Cut the chicken into cubes approx. 2 cm in size and add them to the marinade. Mix well making sure the chicken is well coated. Add the mushrooms and mix. Cover and refrigerate for at least 20 minutes, turning occasionally.
  2. Skewer the chicken and mushrooms.
  3. Pre-heat grill to 220°C and set the probe to 75°C. Insert the probe into the centre of the largest piece of chicken and cook until the probe alarm goes off. Discard any remaining marinade.

## **REFRESHING GREEK LAMB BURGER Serves: 6**

Preparation time: 10-15 minutes plus 20 minutes refrigeration time. Cooking time: approx. 8-12 minutes

To serve: flat bread, tzatziki, cucumber and red onion

- 500g minced lamb
  - ½ red onion, finely chopped
  - 2 tsp ground cumin
  - 2 tsp smoked paprika
  - 3 cloves garlic, finely chopped
  - 2 tbsp fresh mint, chopped
  - 1 tbsp fresh coriander, chopped
  - 80g pomegranate
  - Salt and cracked black pepper to taste
1. Mix all of the ingredients, except the pomegranate, together. Once combined, add the pomegranate, season and gently mix again. Divide the mixture into six and mould into burger shapes. Cover and refrigerate for 20 minutes.
  2. Pre-heat the grill to 220°C and set the probe to 75°C. Insert the probe into the centre of one of the burgers and cook until the probe alarm goes off.
  3. To serve, place a burger on one edge of a piece of flat bread, top with red onion, cucumber and some tzatziki then fold over the flat bread.

## **BBQ PORK BURGER Serves: 6**

Preparation time: 10-15 minutes plus 20 minutes refrigeration time. Cooking time: approx. 8-12 minutes

To serve: brioche bun, coleslaw, whole grain mustard mayonnaise

- 300g minced pork fillet
  - 200g plain sausage meat
  - 2 tsp Jerk seasoning
  - 30g BBQ sauce
  - 1 red pepper, finely diced
  - 3 cloves garlic, finely diced
  - ½ red onion, finely diced
  - Salt and white pepper to taste
1. Mix together all ingredients then divide into six and mould into burger shapes. Cover with cling film and refrigerate for 20 minutes.
  2. Pre-heat the grill to 220°C and set the probe to 75°C. Insert the probe into the centre of one of the burgers and cook until the probe alarm goes off.
  3. To serve, cut open a bun, spread some whole grain mustard mayonnaise on one side, add a spoonful of coleslaw and place a burger on top.

## THAI STYLE CHICKEN WRAP Serves: 4

Preparation time: 5-10 minutes. Cooking time: 8-12 minutes

- 2 chicken breasts, skinless and boneless
- 2 tomatoes, sliced
- 1 avocado, sliced
- 2 spring onions, sliced
- 4 tortilla wraps
- Fresh coriander leaves
- Lettuce
- Salt and pepper to taste

Marinade:

- 4 tbsp olive oil
- Juice of 1 lime or lemon
- 2 tbsp sweet chilli sauce
- 1 tbsp soy sauce
- $\frac{3}{4}$  tsp ground cumin
- $\frac{1}{2}$  tsp ginger
- $\frac{1}{2}$  stick of lemon grass, crushed
- 1 clove garlic, crushed
- 1 green chilli, finely diced

1. Whisk the marinade ingredients together. Cut the chicken breasts in half lengthways and add them to the marinade making sure they are well coated. Cover with cling film and leave to marinate in the fridge for at least 2 hours.
2. Pre-heat the grill to 220°C, and set the probe to 75°C. Insert the probe into the centre of the thickest part of the largest chicken breast and cook until the probe alarm goes off. Leave the chicken to cool slightly.
3. Carefully wipe the grill plates clean and warm the tortillas. Remove them from the heat and turn the grill off.
4. Place some lettuce, tomato, avocado, and spring onions on each tortilla then lay a piece of the chicken on top. Add a few coriander leaves and season. Fold the bottom of the tortilla up and over the chicken then fold in the sides to form an envelope.

## BIG WAVE FISH BURGER Serves: 6

Preparation time: 10-15 minutes plus 20 minutes refrigeration time. Cooking time: approx. 8-10 minutes

To serve: sesame seed bun, lettuce, tartare sauce

- 300g minced white fish – e.g. plaice or cod
- 200g white fish, diced into approx.  $\frac{1}{2}$  cm pieces
- 1 shallot, finely chopped
- 40g capers, washed, drained, dried and chopped
- 3 tsp lemon zest
- 2 tbsp fresh flat leaf parsley, chopped
- 1 free range egg white
- 60g breadcrumbs
- Salt to taste

1. Mix the fish, shallot, capers, lemon zest, parsley and salt together.
2. Crack the egg and lightly beat before adding it to the fish mixture and mixing again. Slowly mix in the breadcrumbs. Divide into six and mould into burger shapes. Cover with cling film and refrigerate for 20 minutes.
3. Pre-heat the grill to 220°C and set the probe to 75°C. Insert the probe into the centre of one of the burgers and cook until the probe alarm goes off.
4. To serve, cut the bun in half, place some lettuce on one half, lay the burger on top then add a spoonful of tartare sauce.

## HEARTY VEGETABLE BURGER Serves: 6

Preparation time: 10-15 minutes plus 20 minutes refrigeration time. Cooking time: approx. 8-10 minutes

To serve: whole grain burger bun, grilled haloumi, grilled courgette, lettuce

- 400g green lentils, cooked, drained and slightly crushed
- 100g chickpeas, cooked, drained and slightly crushed
- 1 carrot, finely grated
- 100g celeriac, finely grated
- $\frac{1}{2}$  white onion, finely diced
- 4 cloves garlic, finely diced
- 2 tbsp thyme leaves
- 2 sprigs thyme
- 4 tbsp olive oil
- 160g butternut squash flesh, roasted and cooled slightly
- 2 tsp chilli flakes
- 1 tsp smoked paprika
- 1  $\frac{1}{2}$  tsp ground mace
- 2 tsp Cajun spice
- 180g breadcrumbs, fine
- Salt and cracked black pepper to taste

1. Mix all ingredients together. Divide the mix into six and mould into burger shapes. Cover with cling film and refrigerate for 20 minutes.
2. Pre-heat the grill to 220°C and cook the burgers for 6-8 minutes depending on how thick they are.
3. To serve, cut a bun in half and lightly grill. Add the lettuce then the burger and top with the grilled haloumi and courgettes.

### **FIRECRACKER CHICKEN BURGER Serves: 6**

Preparation time: 10-15 minutes plus 20 minutes refrigeration time. Cooking time: approx. 8-10 minutes

To serve: ciabatta bun, tomato, red pepper, lettuce, chilli mayonnaise

- 400g minced chicken leg
- 100g minced chicken breast
- 100g chorizo
- 1 red pepper, finely diced
- ½ red onion, finely diced
- 2 tbsp fresh basil, chopped
- 20 drops tabasco sauce
- 2 tsp chilli flakes
- 80g manchego or cheddar cheese
- Salt and white pepper to taste

1. Mix all of the ingredients together. Divide the mix into six and mould into burger shapes. Cover with cling film and refrigerate for 20 minutes.
2. Pre-heat the grill to 220°C and set the probe to 75°C. Insert the probe into the centre of one of the burgers and cook until the probe alarm goes off.
3. To serve, cut a bun in half and lightly grill. Add lettuce and tomato then a burger and top with some mayonnaise and peppers.

### **BIG SUMMER BONANZA BURGER Serves: 6**

Preparation time: 10-15 minutes plus 20 minutes refrigeration time. Cooking time: approx. 8-10 minutes

To serve: sesame bun, avocado, pancetta, tomato, gherkin, burger relish, lettuce, fried egg, cheese

- 500g steak mince - high quality cut
- ½ white onion, finely diced
- 4 cloves garlic, finely diced
- 2 tbsp tomato ketchup
- 1 tbsp English mustard
- 3 tbsp fresh flat leaf parsley, chopped
- Salt and cracked black pepper to taste

1. Mix all ingredients together. Divide the mix into six and mould into burger shapes. Cover with cling film and refrigerate for 20 minutes.
2. Pre-heat the grill to 220°C and set the probe to 75°C. Insert the probe into the centre of one of the burgers and cook until the probe alarm goes off.
3. To serve, cut a bun in half and lightly grill. Put a spoonful of burger relish on the bottom half with some lettuce, tomato and gherkin. Add the burger, top with cheese, avocado, a fried egg and pancetta.

### **PUMPKIN AND ROSEMARY BURGER Serves: 6**

Preparation time: 10-15 minutes plus 20 minutes refrigeration time. Cooking time: approx. 8-10 minutes

To serve: sesame seed bun, goat's cheese, red onion relish

- 300g minced beef
- 200g sausage meat
- 100g pumpkin, roasted and slightly crushed
- 15ml olive oil
- 1 tbsp fresh rosemary, chopped
- ½ white onion, finely diced
- 4 cloves garlic, finely diced
- 100g cooked beetroot,
- Salt to taste
- Cracked black pepper to taste

1. Cut the pumpkin into 1 cm pieces. Mix the pieces with olive oil and season. Spread them on a baking tray and roast in a pre-heated oven at 180°C for 15-20 minutes until soft. Allow to cool to room temperature.
2. Mix all of the ingredients together. Divide the mix into six and mould into burger shapes. Cover with cling film and refrigerate for 20 minutes.
3. Pre-heat the grill to 220°C and set the probe to 75°C. Insert the probe into the centre of one of the burgers and cook until the probe alarm goes off.
4. To serve, cut a bun in half and lightly grill. Add some red onion relish, a burger and top with crumbled goat's cheese.

### **WINTER WARMER BURGER Serves: 6**

Preparation time: 10-15 minutes plus 20 minutes refrigeration time. Cooking time: approx. 8-10 minutes

To serve: crusty white bun, parsnip crisps, lettuce, red current mayonnaise

- 50g minced beef
- 150g steak mince
- ½ red onion, finely diced
- 100g prunes, roughly chopped
- 2 tbsp fresh rosemary leaves, chopped
- 3 tsp horseradish sauce
- 80g chestnuts, cooked and roughly chopped
- Salt and cracked black pepper to taste

1. Mix all ingredients together. Divide the mix into six and mould into burger shapes. Cover with cling film and refrigerate for 20 minutes.

- Pre-heat the grill to 220°C and set the probe to 75°C. Insert the probe into the centre of one of the burgers and cook until the probe alarm goes off.
- To serve, cut the bun in half and grill lightly. Add some lettuce then a burger. Top with a spoonful of the red current mayonnaise and some parsnip crisps.

### **TURKEY BURGER Serves: 6**

Preparation time: 10-15 minutes plus 20 minutes refrigeration time. Cooking time: approx. 8-10 minutes

To serve: crusty white bun, brie, streaky bacon, cranberry mayonnaise, lettuce

- 300g minced turkey leg
  - 200g sausage meat
  - ½ white onion, finely diced
  - 3 cloves garlic, finely diced
  - 60g dried apricots, roughly chopped
  - 60g dried cranberries
  - 2 tbsp fresh sage, chopped
  - Salt and white pepper to taste
  - Sage and onion stuffing mix
- Mix all ingredients except the stuffing crumb together well. Divide the mix into six and mould into burger shapes. Cover with cling film and refrigerate for 20 minutes. Remove from the fridge and coat with the dry sage and onion stuffing mix.
  - Pre-heat the grill to 220°C and set the probe to 75°C. Insert the probe into the centre of one of the burgers and cook until the probe alarm goes off.
  - To serve, cut a bun in half and lightly grill. Add some lettuce and then a burger. Top with some brie, bacon and cranberry mayonnaise.

### **QUICK AND EASY GRILLED BANANAS Serves: 2**

Preparation time: 5 minutes. Cooking time: 3-4 minutes

- 2 bananas, peeled
  - 2 tbsp walnuts, finely chopped
  - 2 tbsp golden caster sugar
  - ½ tsp cinnamon
- Mix the walnuts, sugar and cinnamon together. Cut the bananas lengthwise, then across their width.
  - Pre heat the grill to 220°C, and then place the bananas on the grill flat side up. Spoon some of the walnut mixture on top of each piece. Grill for approx. 3-4 minutes until the bananas are warm and the cinnamon and walnuts are slightly glazed.

### **VANILLA FRUIT KEBABS Serves: 4**

Preparation time: 5-10 minutes. Cooking time: 4-6 minutes

- ½ fresh pineapple or a tin of pineapple chunks
  - 1 small orange
  - 2 bananas
  - 2 peaches or nectarines
  - 1 tsp brown sugar
  - 4 tbsp orange juice
  - 2 tsp vanilla extract
  - 150g Greek yoghurt
  - 8 wooden skewers soaked in water and dried
- Cut the fruit into chunks and marinade for 10 minutes in the orange juice, brown sugar and a teaspoon of vanilla extract.
  - Place the marinated fruit pieces onto skewers.
  - Pre-heat the grill to 220°C and grill the skewers for 4-6 minutes.
  - Mix the Greek yoghurt with the remaining vanilla extract to make a dip for the kebabs.

---

## **RECIPES USING THE DEEP PLATE**

- Fit the upper ribbed plate and the deep plate and level the grill.

### **FLAPJACK Serves: 8-10**

Preparation time: 5-10 minutes. Cooking time: 15-20 minutes

- 375g porridge oats
  - 190g butter
  - 190g soft brown sugar
  - 90g golden syrup
  - 120g raisins
  - 100g fudge pieces
- Melt the butter, sugar and syrup in a pan and combine well. Stir in the oats, raisins and fudge pieces.
  - Line the deep plate with grease proof paper and spoon the mixture in making spreading it evenly.
  - Set the grill to 160°C and cook for approximately 15-20 minutes. Once cooked, turn off your grill and leave the flapjack to cool in the deep plate.

## **CHOCOLATE BROWNIES Serves: 8-10**

Preparation time: 10-15 minutes. Cooking time: 25-30 minutes

- 185g butter
- 185g dark chocolate
- 275g golden caster sugar
- 3 large eggs
- Chocolate icing (*optional*):
  - 200g butter
  - 150g chocolate
  - 40 cocoa powder
  - 85g plain flour
  - 100g dark chocolate drops
  - 100g white chocolate drops
  - 280g icing sugar
  - 1 tsp vanilla extract

1. Line the deep plate with grease proof paper.
2. Whisk together the eggs, sugar and vanilla extract until the mix starts to become white and fluffy (approximately 5-6 minutes). Melt the butter and chocolate and mix together well.
3. Pour the chocolate into the egg mix whilst continuously whisking. Sieve the flour and cocoa powder and slowly fold into the chocolate mix making sure it is well combined. Gently stir in the chocolate drops.
4. Pour the brownie mixture evenly into the deep plate.
5. Set the grill to 160°C and cook for approximately 25-30 minutes. Once cooked, turn off your grill and leave the brownie to cool in the deep plate.
6. For the icing, whisk the butter and vanilla until it starts to turn white and fluffy. Melt the chocolate and add it to the butter. Add the sugar to the chocolate whilst continuously whisking.
7. Once the brownie has cooled, cut it into equal portions and pipe icing onto each portion.

## **FRENCH TOAST (Eggy Bread) Serves: 2**

Preparation time: 5-10 minutes. Cooking time: 6-8 minutes

- 2 medium eggs
- 2 slices bread
- 60ml milk
- 30g golden caster sugar
- 1tsp vanilla extract
- 1 tbsp vegetable oil

1. Mix together the milk, eggs, vanilla and sugar. Pour the mixture into a shallow tray. Dip the bread into the mixture, leave for a few seconds then turn the bread over and repeat.
2. Pre heat the grill to 200°C. Add the oil and allow it to heat for a few moments. Carefully place the bread onto the deep plate. Close the lid and cook for 3-4 minutes. Open the lid, turn the bread over then close the lid and cook for a further 3-4 minutes.

## **CHICKEN WITH A WHITE WINE CREAM SAUCE Serves: 2**

Preparation time: 10 – 15 minutes. Cooking time: 20-25 minutes

- 2 chicken breasts, skinless and boneless, cut into approx. 1cm pieces
- 1 tbsp olive oil
- 1 small onion, finely chopped
- 2 cloves garlic, finely chopped
- 3 mushrooms, sliced
- 100ml cream
- 30ml white wine
- Salt and pepper to taste

1. Pre heat the grill to 220°C.
2. Add the oil and allow it to heat for a few moments. Add the chicken, garlic and onions, close the lid and cook for 3 - 5 minutes, stirring occasionally.
3. Add the mushrooms, cream, wine and season, close the lid and cook for 10 - 15 minutes until the chicken is thoroughly cooked, stirring occasionally.

## **BIG OMELETTE Serves: 6-8**

Preparation time: 8-12 minutes. Cooking time: 12-17 minutes

- 8 medium free range eggs
- 250g soft cream cheese
- Salt and pepper to taste

Filling:

- 200g grated cheddar cheese
- 2 mixed peppers, diced
- 4 spring onions, finely sliced
- ½ bunch fresh chives, finely sliced

1. Mix together the eggs, cream cheese and seasoning. Add the remaining ingredients and mix well.
  2. Pre heat the grill to 175°C. Carefully add the egg mixture and close the lid, cook for 12-17 minutes until cooked through.
- Tip – the filling ingredients can be changed to your preference.

## **GRANOLA Serves: 8-10**

Preparation time: 5-10 minutes. Cooking time: 30-35 minutes

To serve: Greek yoghurt, berry compote, honey, fruit

- 100g maple syrup
- 1 tbsp honey
- 1 tbsp vegetable oil
- 1 tsp vanilla extract
- 150g porridge oats
- 25g sunflower seeds
- 20g sesame seeds
- 20g chia seeds
- 25g pumpkin seeds
- 50g flaked almonds
- 75g sultanas
- 25g desiccated coconut

1. Pre heat the grill to 160°C.
  2. Mix together the maple syrup, honey, vegetable oil and vanilla. Add the porridge, seeds and almonds and mix well.
  3. Put the mixture into the deep plate and cook for 15-20 minutes, stirring regularly.
  4. Add the sultanas and coconut and cook for a further 10-15 minutes, stirring regularly.
  5. Remove and allow to cool.
- Top tip – to make this recipe gluten-free replace the porridge oats with gluten-free porridge oats.

---

## RECYCLING



To avoid environmental and health problems due to hazardous substances, appliances and rechargeable and non-rechargeable batteries marked with one of these symbols must not be disposed of with unsorted municipal waste. Always dispose of electrical and electronic products and, where applicable, rechargeable and non-rechargeable batteries, at an appropriate official recycling/collection point.

---

## SERVICE

If you ring Customer Service, please have the model number to hand, as we won't be able to help you without it. It's on the rating plate (usually underneath the product).

The product isn't user-serviceable. If it's not working, read the instructions, check the plug fuse and main fuse/circuit breaker. If it's still not working, consult your retailer.

If that doesn't solve the problem – ring Customer Service – they may be able to offer technical advice.

If they advise you to return the product to us, pack it carefully, include a note with your name, address, day phone number, and what's wrong. If under guarantee, say where and when purchased, and include proof of purchase (till receipt). Send it to: Customer Service

Spectrum Brands (UK) Ltd

Fir Street, Failsworth, Manchester M35 0HS

email: [support@georgeforeman.co.uk](mailto:support@georgeforeman.co.uk)

telephone: 0345 230 0598 (local rate number)

---

## GUARANTEE

Defects affecting product functionality appearing within two years of first retail purchase will be corrected by replacement or repair provided the product is used and maintained in accordance with the instructions. Your statutory rights are not affected. Documentation, packaging, and product specifications may change without notice.

---

## ONLINE/SPARES

[www.georgeforemangrills.com](http://www.georgeforemangrills.com) for more products and/or spares

---

## REGISTER ONLINE FOR –

 £10,000 prize draw,

 EXTRA year guarantee,

 FREE rewards gallery

Visit [www.georgeforeman.co.uk/productregister](http://www.georgeforeman.co.uk/productregister)

You must register within 28 days of purchase.